

— —

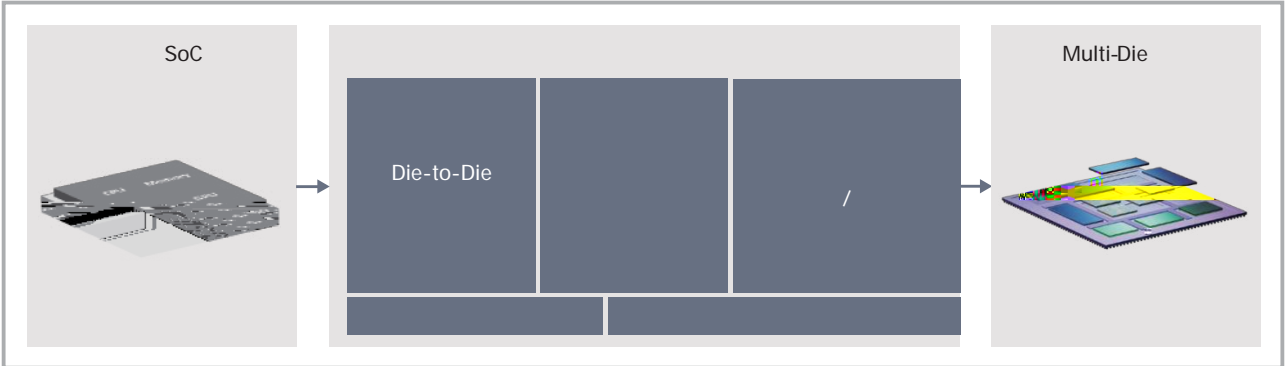



4

Multi-Die





Multi-Die

/





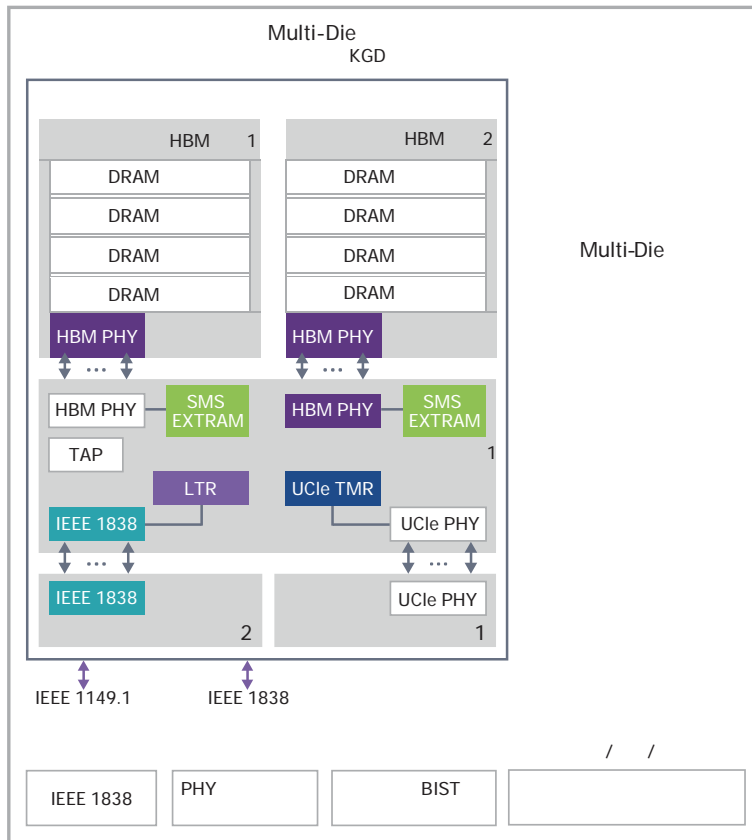



---

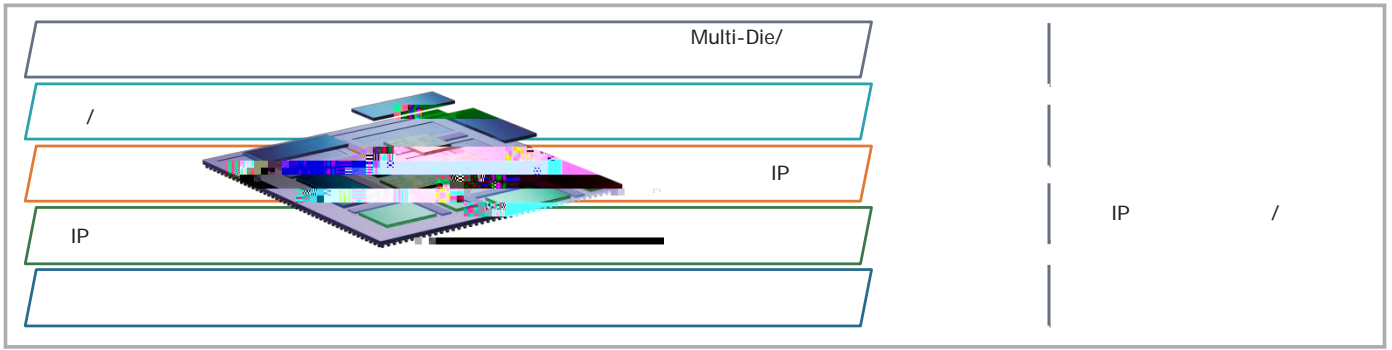

9

Multi-Die

---



---



---



---